

The Most Common P2 Volvo Front Suspension Noise

So you're in your ride cruising down the streets when all of a sudden you hear a knocking noise coming from the front suspension. Now, most of us love our Volvos and have come to know that there are several things that could cause knocking or clunking in our front ends, but one of the weakest links are the rubber upper spring seats. Whenever I hear a noise from the front end of a Volvo this is my number one thing to check out.

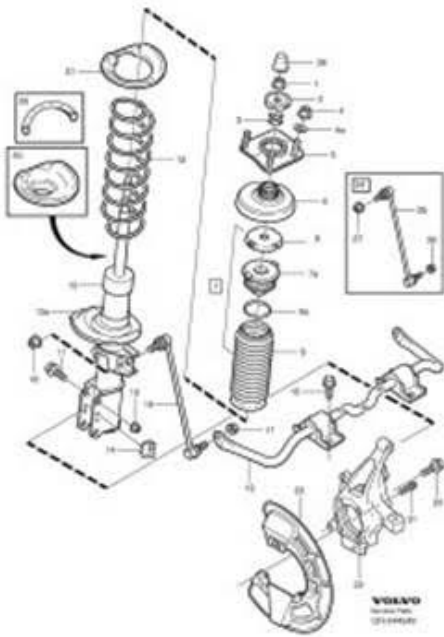

The upper spring seat carries the load of the front coil spring force and essentially takes the most abuse in the front end of these vehicles. If possible, first verify that the noise is coming from the spring seat which can be diagnosed properly using a set of chassis ears but chances are you won't need them if the failure is bad enough. When these seats blow out, you know it. If you're still unsure if the noise is coming from the seats you can remove the upper strut nut and washer from inside the engine bay with the strut still installed. The nut and washer can be seen in the diagram to the left and are numbered 1 and 2. Once these are removed you'll see the "T nut" and will be able to better gauge the condition of the seat. If the metal sleeve is misaligned, cracked, worn or broken, replace the spring seat.

Now, for the upgrade, instead of replacing the spring seat with the factory design, replace the spring seat with the more durable, heavy duty [Volvo XC90](#) spring seat part number 30683637. The XC90's spring seats were made to withstand more abuse and will last a lot longer on your vehicle. You can find the updated [Volvo P2 Upper Strut Mount and Spring Seat Kit on FCP Euro](#).



This upgrade can be performed on the following vehicles:

- S80 - 1999-2006**
- XC90 - 2003-2014**
- V70 - 2001-2007**
- V70 XC / XC70 - 2001-2007**
- S60 - 2001-2009**

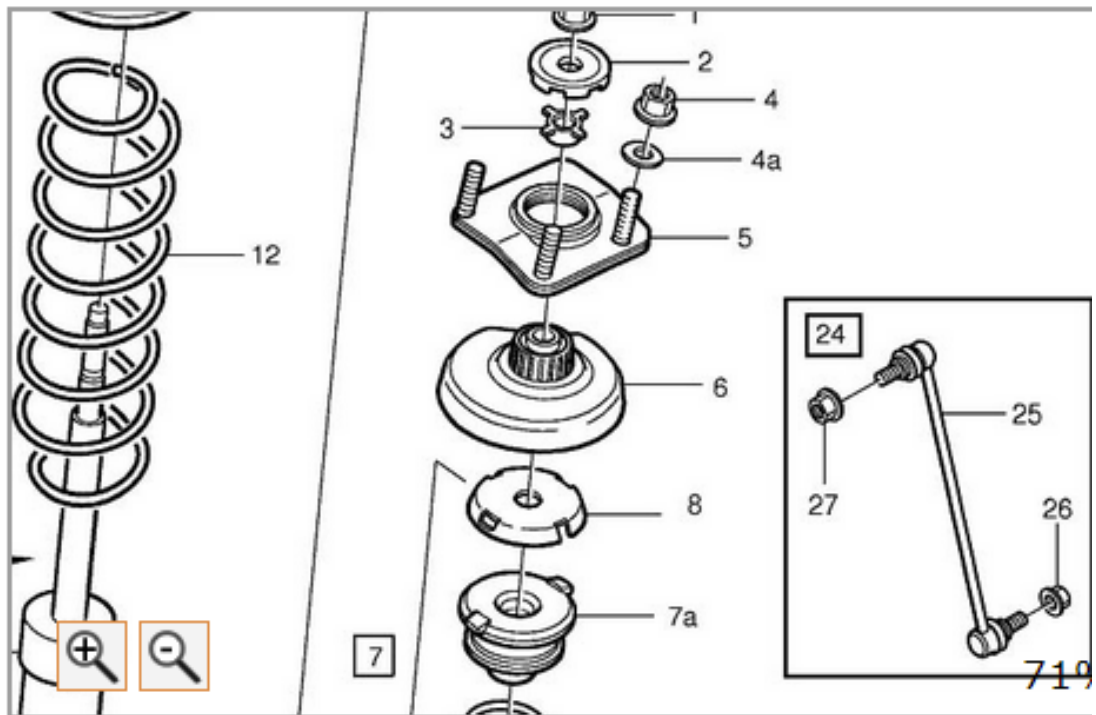

#6 is the spring seat.. This has solved clunking or binding problems.
30683637